

Technical sheet :

1700 R



Capacities		Metric
Rated Operating Capacity		769 kg
Unladen weight		2885 kg
Weight and dimensions		
Overall Operating Height - Fully Raised	h27	3920 mm
Height to Hinge Pin - Fully Raised	h28	2938.5 mm
Overall Height to Top of ROPS	h17	1985 mm
Dump angle at full height	a5	43.5 °
Dump height	h29	2133 mm
Overall length with bucket	l16	3178 mm
Dump reach at full height		655 mm
Seat to ground height	h30	952.5 mm
Wheelbase	y	965 mm
Overall width less bucket	b1	1600 mm
Bucket Width	e1	1600 mm
Ground clearance	m4	165 mm
Overall length - Less Bucket	l2	2472 mm
Departure angle	a2	21 °
Clearance Radius - Front with Bucket		1847 mm
Clearance Circle - Rear	wa1	1526 mm
Performances		
Travel speed (unladen)		11.9 km/h
Wheels		
Standard tyres		10X 16.5 - 10 PR Heavy Duty
Tyres type		Pneumatic
Number of drive wheels		4
Engine		
Engine brand		Simpson
Engine model		TSJ436
Engine norm		BS III CEV
Gross Power (kW)		60 Hp
Battery		12 V
Starter (kW)		2 kW
Hydraulics		
Auxiliary Hydraulic Pressure		2750 Bar
High-Flow Auxiliary Hydraulics - Option		70 l/min
Tank capacities		
Fuel tank		53 l
Displacement		3.60 l
Coolant system capacity		7 l
LH Chain case		7.50 l
RH Chain case		7.50 l

Dimensional drawing

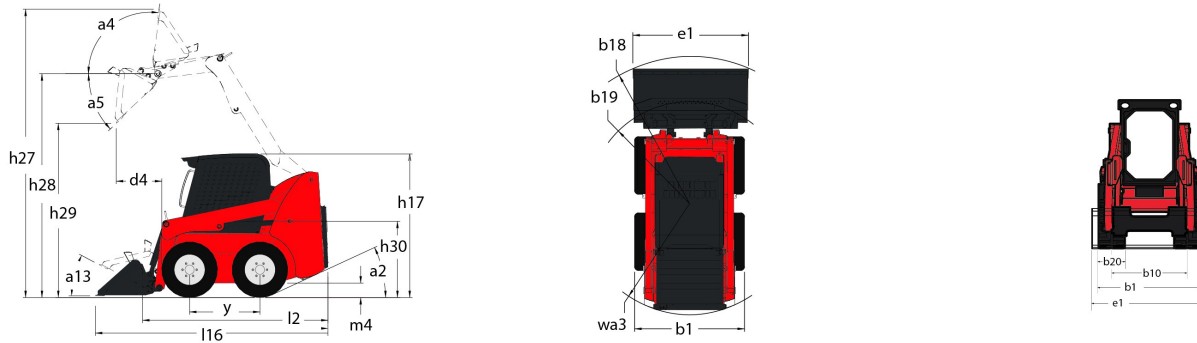

Equipment

Lifting function	
All-Tach® Attachment Mounting System	Standard
Auxiliary Hydraulics	Standard
Lighting	
Work Lights - Front and Rear	Standard
Operator station	
Cabin Rops and fops level I	Standard
Hand/Foot Controls	Standard
Horn	Standard
Sound Reduction Material	Standard
Suspension Seat - Mechanical	Standard
Safety	
Anti-Vandalism Protection	Standard
Back-Up Alarm	Standard
Hydraloc™ Safety System	Standard
Operator Restraint Bar	Standard
Secondary functions	
Full Instrumentation	Standard



Siège Social
430 rue de l'Aubinière - 44150 Ancenis Cedex - France
Tel: +33(0)2 40 09 10 11 - Fax: +33 (0)2 40 09 10 97
www.manitou.com



This brochure describes versions and configuration options for Manitou products which may be fitted with different equipment. The equipment described in this brochure may be standard, optional or not available depending on version. Manitou reserves the right to change the specifications shown and described at any time and without prior warning. The manufacturer is not liable for the specifications given. For more information, contact your Manitou dealer. Non-contractual document. Product descriptions may differ from actual products. List of specifications is not comprehensive. The logos and visual identity of the company are the property of Manitou and may not be used without authorisation. All rights reserved. The photos and diagrams contained in this brochure are provided for information only.

MANITOU BF SA - Limited company with board of directors - Share capital: 39,668,399 euros - 857 802 508
RCS Nantes